

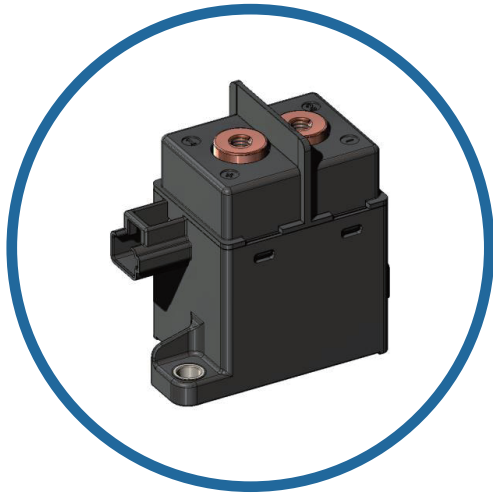

# High Voltage DC Contactor

SGX050 50A CERAMIC CONTACTOR



## Feature

- Hermetically seal rated to 175°C – Reduced risk of fire or meltdown in over current conditions.
- Backfilled with gas (primarily hydrogen) to effectively inhibit oxidation, resulting in low and stable contact resistance.
- The insulation resistance stands at 1000MΩ (1000Vdc), while the dielectric strength between the coil and contacts reaches 4.0kV.
- Continuous current carry 50A at 85°C,
- Comply with IEC 60664-1 and RoHS standards.

## Applications

- Material Handling
- Residential ESS
- DC Fast Charging

## SPECIFICATIONS

### Contact data

Specifications	Data
Contact Arrangement	1 Form A
Contact Resistance	≤0.5mΩ @ 200A
Rated Load Current	50A
Rated Switching Voltage	1000Vdc
Rated Switching Power	112.5kW
Min. Applicable Load	6Vdc, 1A
Max. Switching Voltage	1000Vdc
Max. Switching Power	112.5kW(750Vdc)
Max. Breaking Current	1500A(750Vdc),1cycle

### Characteristics

Specifications	Data	
Dielectric Strength	Between Open contacts	4300Vac, 1min
	Between Coil&Contacts	4300Vac, 1min
Insulation Resistance	1000MΩ at 1000Vdc	
Operate Time (at nomi. volt.)	≤30ms	
Release Time (at nomi. volt.)	≤10ms	
Vibration Resistance (sine)	10Hz~500Hz, 49m/s <sup>2</sup>	
Shock Resistance	Functional Open:	196m/s <sup>2</sup>
	Functional Close:	490m/s <sup>2</sup>
	Destructive:	490m/s <sup>2</sup>
Ambient Temperature	-40°C~85°C	
Humidity	5% RH~85% RH	
Termination	M6 female screw	
Mounting	M5 screw	
Unit Weight	Approx.270g	
Outline Dimensions	76.5mm X 39mm X 70mm	



## Coil

Nominal Voltage Vdc	Pick-up Voltage Vdc	Drop-out Voltage Vdc	Coil Power W
12	≤9	≥1	~6.0 @23°C
24	≤18	≥2	

Notes: The values above are conservative values within the temperature range (-40°C to 85°C).

## Endurance

Specifications		Data
Electrical Endurance	Capacitive load	Switch on: $2 \times 10^4$ cycles (37.5Vdc, C=1100uF, inrush 400A, steady 150A)
	Resistive load	Switch: 500cycles (750Vdc, 50A) Switch: 6000 cycles (1000Vdc, 20A)
Current Endurance		50A, cont.
		180A, 2h
		225A, 15min
		320A, 2min
		400A, 1min
		600A, 20s
	900A, 8s	
Mechanical Endurance		$2 \times 10^5$ cycles, on-off ratio: 0.5s : 0.5s

## DIMENSIONS

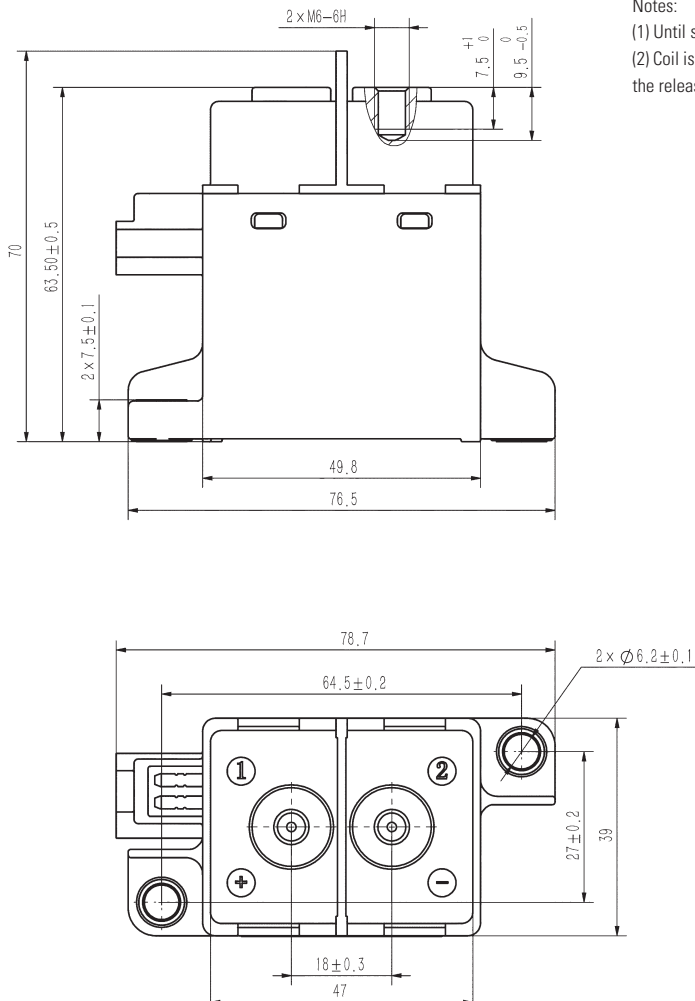

### Notes:

- Until special statement, the temperature of electrical endurance is at 23°C and the on-off ratio is 0.6s : 5.4s.
- Coil is not connected to surge suppressor during tests. Attention: If the coil is used in parallel with the diode, the release time of the contactor will be prolonged and the service life will be reduced.

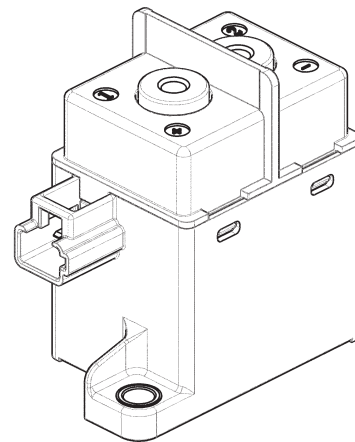

General Tolerance	
Outline Dimension	Tolerance
≤10mm	+0.3mm
10mm-50mm	+0.6mm
>50mm	+1.0mm



## ● INSTALLATION

### ① Wiring Diagram

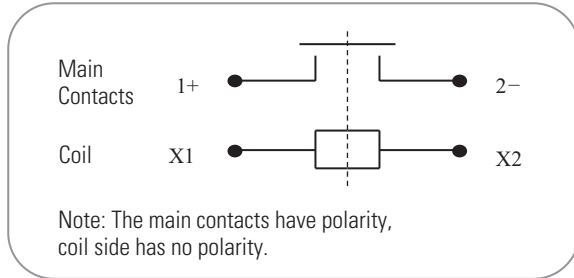

### ② Recommended connector

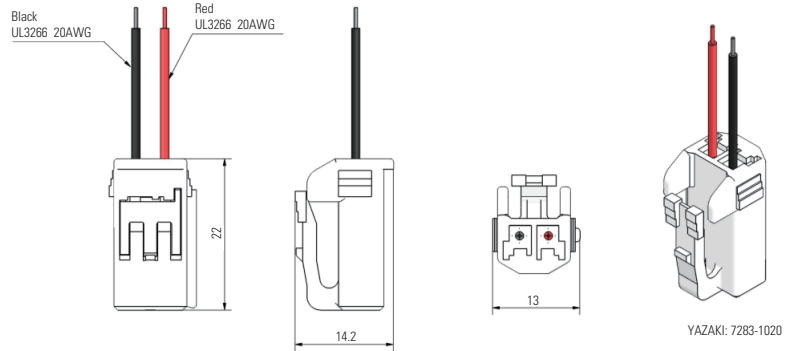

### ③ Installation Torque

Load Terminal Installation				
Installation Mode	Screw Installation Depth	Torque	Copper Busbar Diameter	Copper Busbar Thickness
M6 Screw	7.0mm~8.5mm	6N·m~8N·m	6.0mm~6.5mm	2.0mm~3.0mm

Contactor Installation	
Installation Mode	Torque
M5 Screw	3N·m~4N·m

Note:

- In order to prevent loosening, please use extra washer when installing relay: spring washer + flat washer.
- Please avoid grease and other foreign matter in the terminal, please use the connecting wire with a cross section area  $\geq 50\text{mm}^2$ , otherwise they may cause abnormal heating in the terminal part.
- When installing the contactor at the load using an electric screwdriver, it is recommended to use a three stage step speed mode: the first stage 35rpm, the second stage (100-150) rpm, and the third stage 35rpm.

## ● ORDERING OPTIONS

Example SGX051CXX

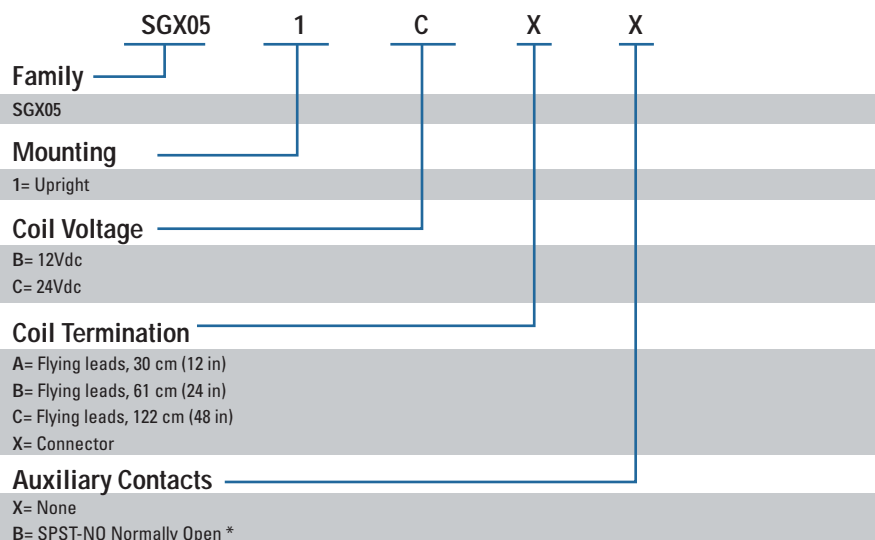

Note\*:  
in development



## WARNINGS



### RISK OF MATERIAL DAMAGE AND HOT ENCLOSURE

- The product's side panels may be hot, allow the product to cool before touching
- Follow proper mounting instructions including torque values
- Do not allow liquids or foreign objects to enter this product

**Failure to follow these instructions can result in serious injury, or equipment damage.**



### HAZARD OF ELECTRIC SHOCK, EXPLOSION OR ARC FLASH

- Disconnect all power before installing or working with this equipment
- Verify all connections and replace all covers before turning on power

**Failure to follow these instructions will result in death or serious injury.**

Sensata Technologies, Inc. ("Sensata") datasheets are solely intended to assist designers ("Buyers") who are developing systems that incorporate Sensata products (also referred to herein as "components"). Buyer understands and agrees that Buyer remains responsible for using its independent analysis, valuation, and judgment in designing Buyer's systems and products. Sensata datasheets have been created using standard laboratory conditions and engineering practices. Sensata has not conducted any testing other than that specifically described in the published documentation for a particular datasheet. Sensata may make corrections, enhancements, improvements, and other changes to its datasheets or components without notice.

Buyers are authorized to use Sensata datasheets with the Sensata component(s) identified in each particular datasheet. HOWEVER, NO OTHER LICENSE, EXPRESS OR IMPLIED, BY ESTOPPEL OR OTHERWISE TO ANY OTHER SENSATA INTELLECTUAL PROPERTY RIGHT, AND NO LICENSE TO ANY THIRD PARTY TECHNOLOGY OR INTELLECTUAL PROPERTY RIGHT, IS GRANTED HEREIN. SENSATA DATASHEETS ARE PROVIDED "AS IS". SENSATA MAKES NO WARRANTIES OR REPRESENTATIONS WITH REGARD TO THE DATASHEETS OR USE OF THE DATASHEETS, EXPRESS, IMPLIED, OR STATUTORY, INCLUDING ACCURACY OR COMPLETENESS. SENSATA DISCLAIMS ANY WARRANTY OF TITLE AND ANY IMPLIED WARRANTIES OF MERCHANTABILITY, FITNESS FOR A PARTICULAR PURPOSE, QUIET ENJOYMENT, QUIET POSSESSION, AND NON-INFRINGEMENT OF ANY THIRD PARTY INTELLECTUAL PROPERTY RIGHTS WITH REGARD TO SENSATA DATASHEETS OR USE THEREOF.

All products are sold subject to Sensata's terms and conditions of sale supplied at [www.sensata.com](http://www.sensata.com). SENSATA ASSUMES NO LIABILITY FOR APPLICATIONS ASSISTANCE OR THE DESIGN OF BUYERS' PRODUCTS. BUYER ACKNOWLEDGES AND AGREES THAT IT IS SOLELY RESPONSIBLE FOR COMPLIANCE WITH ALL LEGAL, REGULATORY, AND SAFETY-RELATED REQUIREMENTS CONCERNING ITS PRODUCTS, AND ANY USE OF SENSATA COMPONENTS IN ITS APPLICATIONS, NOTWITHSTANDING ANY APPLICATIONS-RELATED INFORMATION OR SUPPORT THAT MAY BE PROVIDED BY SENSATA.

Mailing Address: Sensata Technologies, Inc., 529 Pleasant Street, Attleboro, MA 02703, USA

## CONTACT US

### Americas

Sensata GIGAVAC  
Contactor Center of Excellence  
6382 Rose Lane  
Carpinteria, CA 93013  
USA  
Tel: +1(805) 684 8401  
Email: [gigavac@sensata.com](mailto:gigavac@sensata.com)  
Sensata Global Headquarters  
Sensata Technologies  
529 Pleasant Street  
Attleboro, MA 02703  
USA  
**Europe, Middle East & Africa**  
Sensata Technologies Holland B.V.  
Jan Tinbergenstraat 80  
7559 SP Hengelo  
The Netherlands  
Tel: +31743578000  
Email: [gigavac-info-eu@list.sensata.com](mailto:gigavac-info-eu@list.sensata.com)

### Asia Pacific

China  
Sensata Technologies China Co., Ltd.  
BM Intercontinental Business Center  
30th Floor  
100 Yu Tong Road  
Shanghai 200070  
People's Republic of China  
Tel: +8621 2306 1500  
Email: [contactorasia@list.sensata.com](mailto:contactorasia@list.sensata.com)  
Japan  
Sensata Technologies Japan Ltd.  
Shin Yokohama Square Bldg.7F  
2-3-12 Shin-yokohama  
Kohoku-ku, Yokohama-shi,  
Kanagawa 222-0033  
Tel: +81 45 277 7001  
Email: [contactorasia@list.sensata.com](mailto:contactorasia@list.sensata.com)